

EXAMPLE OF PART CODING:			
TIPALOY		R.W.M.A.	
0	= POINTED NOSE	D	= "D" NOSE
2	= #5RW TAPER	02	= CLASS 2 COPPER
250	= 2.50" LONG	5	= #5RW TAPER
		10	= LENGTH IN 1/4"

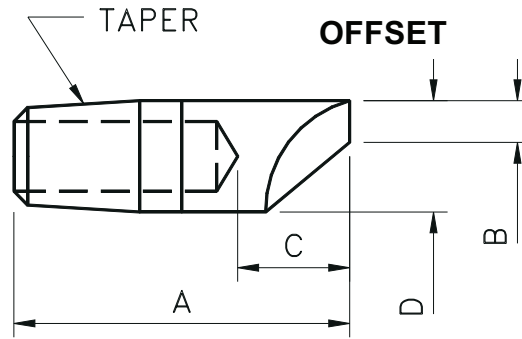

TAPER	CLASS 2		CLASS 1		CLASS 3		OVERALL	WELD	FACE TO	MAJOR
	CODE	RWMA CODE #	CODE	RWMA CODE #	CODE	RWMA CODE #	LENGTH A	FACE DIA. B	WATER HOLE C	DIA. D
	01-100	D02404	01-100-100	D01404	-	-	1			
	01-125	D02405	01-125-100	D01405	01-125-200	D03405	1-1/4			
	01-150	D02406	01-150-100	D01406	01-150-200	D03406	1-1/2			
4 RW	01-175	D02407	01-175-100	D01407	01-175-200	D03407	1-3/4			
OR	01-200	D02408	01-200-100	D01408	01-200-200	D03408	2			
# 1MT	01-225	D02409	01-225-100	D01409	01-225-200	D03409	2-1/4	3/16	1/2	.482
	01-250	D02410	01-250-100	D01410	01-250-200	D03410	2-1/2			OR
	01-275	D02411	01-275-100	D01411	01-275-200	D03411	2-3/4			.500
	01-300	D02412	01-300-100	D01412	01-300-200	D03412	3			
	01-325	D02413	01-325-100	D01413	01-325-200	D03413	3-1/4			
	01-350	D02414	01-350-100	D01414	01-350-200	D03414	3-1/2			
	01-375	D02415	01-375-100	D01415	01-375-200	D03415	3-3/4			
	01-400	D02416	01-400-100	D01416	01-400-200	D03416	4			
	02-125	D02505	02-125-100	D01505	02-125-200	D03505	1-1/4			
	02-150	D02506	02-150-100	D01506	02-150-200	D03506	1-1/2			
	02-175	D02507	02-175-100	D01507	02-175-200	D03507	1-3/4			
	02-200	D02508	02-200-100	D01508	02-200-200	D03508	2			
5 RW	02-225	D02509	02-225-100	D01509	02-225-200	D03509	2-1/4			
OR	02-250	D02510	02-250-100	D01510	02-250-200	D03510	2-1/2	1/4	3/4	.625
# 2MT	02-275	D02511	02-275-100	D01511	02-275-200	D03511	2-3/4			
	02-300	D02512	02-300-100	D01512	02-300-200	D03512	3			
	02-325	D02513	02-325-100	D01513	02-325-200	D03513	3-1/4			
	02-350	D02514	02-350-100	D01514	02-350-200	D03514	3-1/2			
	02-375	D02515	02-375-100	D01515	02-375-200	D03515	3-3/4			
	02-400	D02516	02-400-100	D01516	02-400-200	D03516	4			
	06-200	D02608	06-200-100	D01608	06-200-200	D03608	2			
6 RW	06-250	D02610	06-250-100	D01610	06-250-200	D03610	2-1/2	9/32	3/4	.750
	06-300	D02612	06-300-100	D01612	06-300-200	D03612	3			
	03-200	D02708	03-200-100	D01708	03-200-200	D03708	2			
7 RW	03-250	D02710	03-250-100	D01710	03-250-200	D03710	2-1/2	5/16	3/4	.875
OR	03-300	D02712	03-300-100	D01712	03-300-200	D03712	3			
# 3MT	03-400	D02716	03-400-100	D01716	03-400-200	D03716	4			

OFFSET ELECTRODES