

## CT FACED & OFFSET ELECTRODES

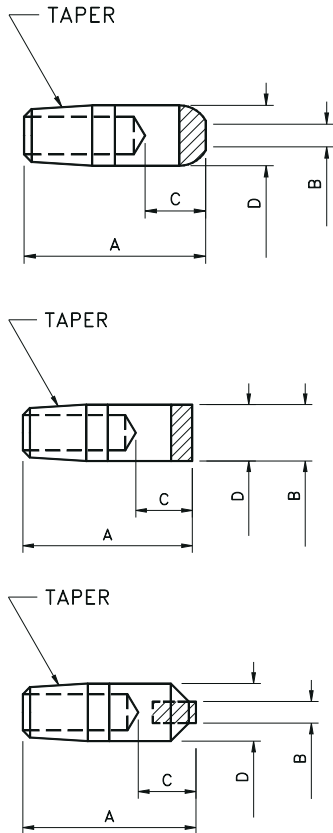

TAPER	T10W CU/TUNG FACING CODE NO.	T100W TUNGSTEN FACING CODE NO.	T100M MOLLY FACING CODE NO.	OVERALL LENGTH A	WELD FACE DIA. B	FACE TO WATER HOLE C	MAJOR DIA. D
<b>DOMES - CT FACED</b>							
4RW / #1MT	CT-1578	CT-1577	M-1579	2	1/8	3/8	.500
5RW / #2MT	CT-1581	CT-1580	M-1582		1/8		.625
7RW / #3MT	CT-1584	CT-1583	M-1585		1/4		.875
<b>FLAT - CT FACED</b>							
4RW / #1MT	CT-1587	CT-1586	M-1588		1/2		.500
5RW / #2MT	CT-1590	CT-1589	M-1591	2	5/8	3/8	.625
7RW / #3MT	CT-1593	CT-1592	M-1594		7/8		.875
<b>CENTER INSERTED</b>							
4RW / #1MT	H-147400	CT-147400	M-147400		3/16	1/2	.500
5RW / #2MT	H-147500	CT-147500	M-147500	2	1/4	9/16	.625
7RW / #3MT	H-147600	CT-147600	M-147600		3/8	11/16	.875

**COPPER TUNGSTEN, TUNGSTEN, AND MOLYBDENUM ARE ALSO AVAILABLE IN CUT-TO-LENGTH INSERTS, IN 8" OR 12" LENGTHS, AND IN ROUND OR RECTANGULAR SHAPES.**

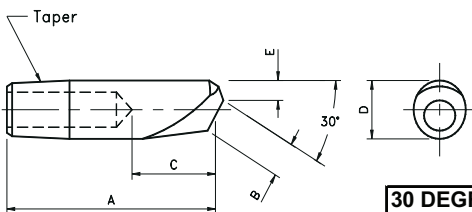

<b>30 DEGREE OFFSET</b>						
TAPER	#130 CODE NO.	LENGTH TO CENTER OF FACE A	WELD FACE DIA. B	FACE TO WATER HOLE C	MAJOR DIA. D	CLEARANCE DISTANCE E
4RW / #1MT	SP-219-1	2	1/4		.482 / .500	3/16
5RW / #2MT	SP-219-2	2-1/2	3/8	2-1/2	0.625	1/4
7RW / #3MT	SP-219-3	3	1/2		0.875	5/16

**SPECIAL OFFSET TIPS CAN BE MANUFACTURED TO YOUR SPECIFICATIONS INCLUDING BUTTON STYLE, LOW PROFILE-ELECTRODE TAPER STYLE, AND VARIATIONS OF THE STANDARDS SHOWN ABOVE.**

**CT FACED & OFFSET ELECTRODES**