



300 SERIES PREMIUM (EJECTOR) WATER COOLED ELECTRODE HOLDERS

Phone: 888-654-9353

Fax: 937-253-2324

Email: sales@productionengineering.com

300 SERIES PREMIUM (EJECTOR) WATER COOLED ELECTRODE HOLDER

CMW Premium holder barrels are made from high strength RWMA CLASS 2 material, centerless ground within .002" tolerance on diameter and nickel plated to resist wear and assure uniform contact resistance of a low magnitude.



300 SERIES TAPERED HOLDER					
Part No. Holder Assy.	Major Taper Dia. A	Barrel Dia. B	Barrel Length C	RW Taper D	Engagement With Std. Elect. E
18-317	.625	1-1/4	8	5 RW	3/4
18-318	.625	1-1/2		5 RW	3/4
18-319*	.875	1-1/4	8	7 RW	1-1/8
18-320*	.875	1-1/2		7 RW	1-1/8
18-337	.625	1-1/4	12	5 RW	3/4
18-338	.625	1-1/2		5 RW	3/4
18-339*	.875	1-1/4	12	7 RW	1-1/8
18-340*	.875	1-1/2		7 RW	1-1/8

*Must use knockout adapter 18-20033

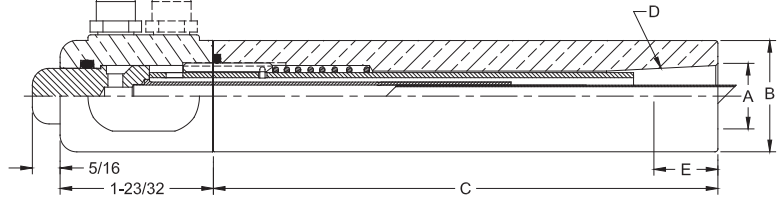
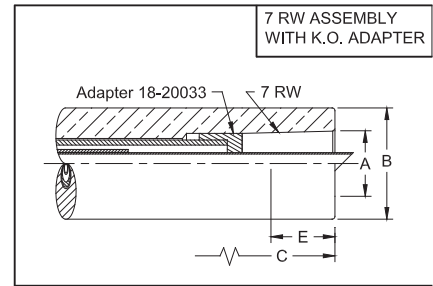
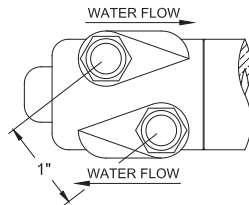

300 SERIES THREADED HOLDER				
Part No. Holder Assy.	Barrel Dia. B	Barrel Length C	Thread Size D	Engagement With Std. Elect. E
18-372	1	8	7/8-14	9/16
18-373	1-1/4		7/8-14	9/16
18-375	1-1/4	8	1-14	3/4
18-376	1-1/2		1-14	3/4

300 Series Threaded Holder can use Male Threaded to Female Taper Universal Adapters on page 46.

Note: These threaded holder barrels are the same as on 600 series holders on page 44.

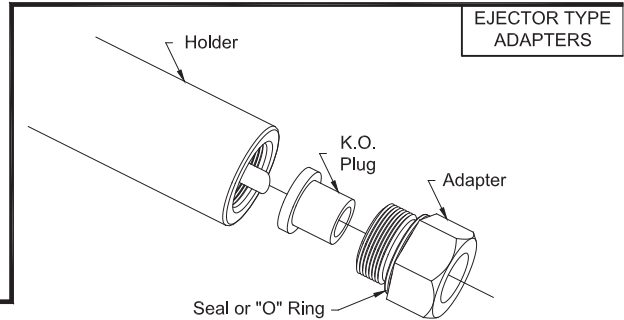
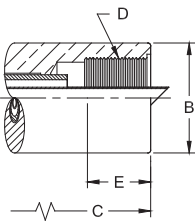

EJECTOR TYPE ADAPTERS

EJECTOR TYPE ADAPTERS 7/8-14 THREAD								
Adapter Part No.	Male Thd. Size L	Female Taper		Length Under Hd. M	Hex. Over Flats H	Overall Length C	Sealing Ring Part No.	K.O. Plug Part No.
		Size D	Major Dia.					
18-7702	7/8-14	4 RW	.463	5/8	1	13/16	18-76460	18-78501
18-7712	7/8-14	5 RW	.625	1/2	1	1-1/16	18-76460	18-7712-3

Use with Threaded Ejector Holder to make Replaceable Taper Holders

Part No.	Female Thd. Size	Barrel Dia.
18-372	7/8-14	1
18-373	7/8-14	1-1/4

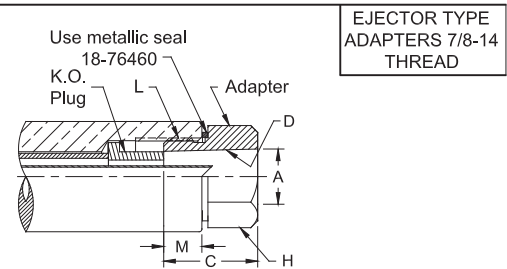

EJECTOR TYPE ADAPTERS 1-14 THREAD								
Adapter Part No.	Male Thd. Size L	Female Taper		Length Under Hd. M	Hex. Over Flats H	Overall Length C	Sealing Ring Part No.	K.O. Plug Part No.
		Size D	Major Dia.					
18-7852	1-14	4 RW	.463	9/16	1-1/4	13/16	18-10060-17	18-78501
18-7862	1-14	5 RW	.625	7/16	1-1/4	1-1/16	18-10060-17	18-7712-3
18-7864	1-14	6 RW	.750	3/4	1-1/4	1-3/4	18-10060-17	18-78650
18-7872	1-14	7 RW	.875	3/4	1-1/4	2-1/8	18-10060-17	18-78701

Use with Threaded Ejector Holder to make Replaceable Taper Holders

Part No.	Female Thd. Size	Barrel Dia.
18-375	1-14	1-1/4
18-376	1-14	1-1/2

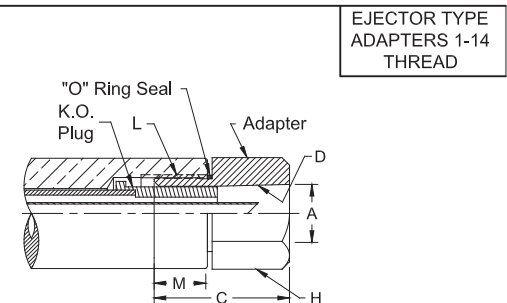

300 SERIES PREMIUM (EJECTOR) REPLACEMENT PARTS



Phone: 888-654-9353

Fax: 937-253-2324

Email: sales@productionengineering.com

300 SERIES PREMIUM (EJECTOR) WATER COOLED ELECTRODE HOLDER

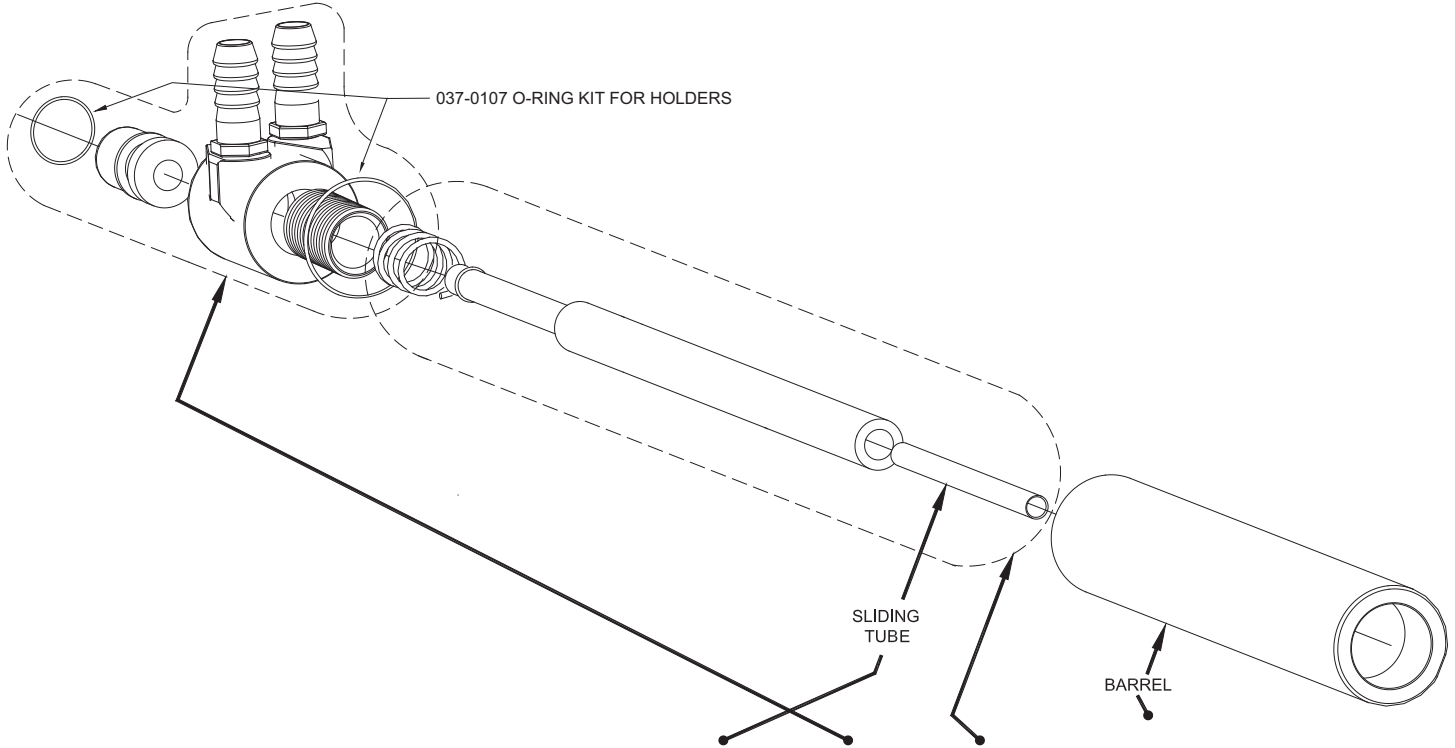

Part No. Holder Assy.	Thread Or Taper	O.A.L	Sliding Tube	Water Conn. HD. Sub-Assy.	K.O. Tube Sub-Assy	Barrel Diameter	Barrel
18-317 18-318	5 RW	8	18-10047-8	18-20092	18-20096-8	1-1/4 1-1/2	18-31710-8 18-31810-8
18-319* 18-320*	7 RW	8	18-10047-8	18-20092	18-20096-58	1-1/4 1-1/2	18-31910-8 18-32010-8
18-337 18-338	5 RW	12	18-10047-8	18-20092	18-20096-12	1-1/4 1-1/2	18-31710-12 18-31810-12
18-339* 18-340*	7 RW	12	18-10047-8	18-20092	18-20096-62	1-1/4 1-1/2	18-31910-12 18-32010-12
18-372 18-373	7/8-14	8	18-10047-8	18-20092	18-20096-8	1 1-1/4	18-37210-8 18-37310-8
18-375 18-376	1-14	8	18-10047-8	18-20092	18-20096-8	1-1/4 1-1/2	18-37510-8 18-37610-8

*Must use knockout adapter 18-20033