

## 200 SERIES (EJECTOR) WATER COOLED ELECTRODE HOLDER

200 SERIES TAPERED HOLDER					
Part No. Holder Assy.	Major Taper Dia. A	Barrel Dia. B	Barrel Length C	RW Taper D	Engagement With Std. Elect. E
18-201 18-202 18-203 18-204	.463	3/4 7/8 1 1-1/4	3	4 RW	1/2
18-206 18-207 18-208	.625	1 1-1/4 1-1/2		5 RW	3/4
18-211 18-212 18-213 18-214	.463	3/4 7/8 1 1-1/4	8	4 RW	1/2
18-216 18-217 18-218	.625	1 1-1/4 1-1/2		5 RW	3/4
18-219* 18-220*	.875	1-1/4 1-1/2		7 RW	1-1/8
18-231 18-232 18-233 18-234	.463	3/4 7/8 1 1-1/4	12	4 RW	1/2
18-236 18-237 18-238	.625	1 1-1/4 1-1/2		5 RW	3/4
18-236-18 18-237-18 18-238-18	.625	1 1-1/4 1-1/2	18	5 RW	3/4

\*Must use knockout adapter 18-20033

200 SERIES THREADED HOLDER				
Part No. Holder Assy.	Barrel Dia. B	Barrel Length C	Thread Size D	Engagement With Std. Elect. E
18-272 18-273 18-274	1 1-1/4 1-1/2	8	7/8-14	9/16
18-275 18-276	1-1/4 1-1/2		1-14	3/4

200 Series Threaded Holder can use Male Threaded to Female Taper Universal Adapters on page 46.

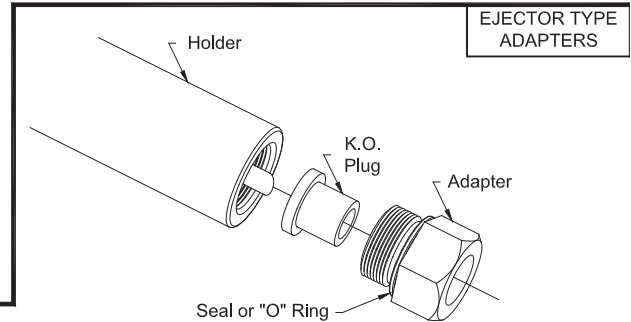
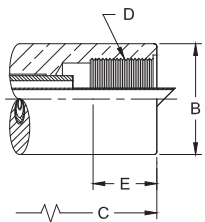
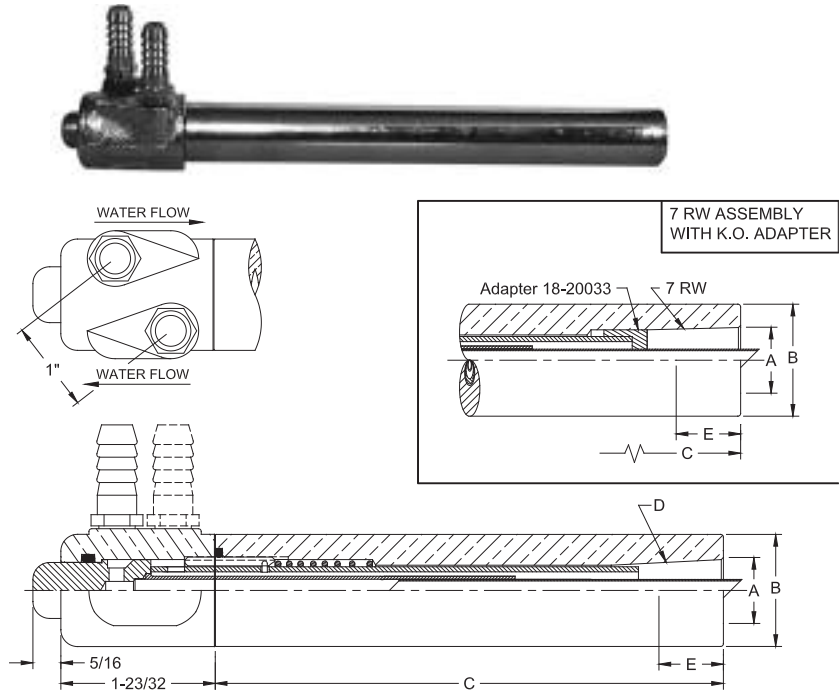

### EJECTOR TYPE ADAPTERS

EJECTOR TYPE ADAPTERS 7/8-14 THREAD								
Adapter Part No.	Male Thd. Size L	Female Taper		Length Under Hd. M	Hex. Over Flats H	Overall Length C	Sealing Ring Part No.	K.O. Plug Part No.
		Size D	Major Dia. A					
18-7702	7/8-14	4 RW	.463	5/8	1	13/16	18-76460	18-78501
18-7712	7/8-14	5 RW	.625	1/2	1	1-1/16	18-76460	18-7712-3

Use with Threaded Ejector Holder to make Replaceable Taper Holders

Part No.	Female Thd. Size	Barrel Dia.
18-272	7/8-14	1
18-273	7/8-14	1-1/4
18-274	7/8-14	1-1/2

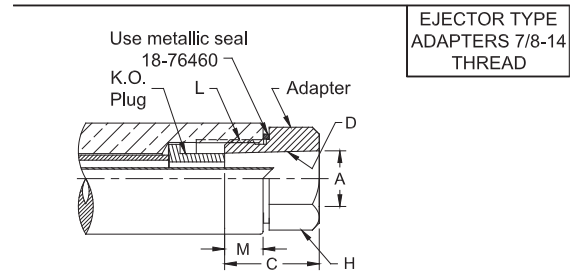

EJECTOR TYPE ADAPTERS 1-14 THREAD								
Adapter Part No.	Male Thd. Size L	Female Taper		Length Under Hd. M	Hex. Over Flats H	Overall Length C	Sealing Ring Part No.	K.O. Plug Part No.
		Size D	Major Dia. A					
18-7852 18-7862	1-14 1-14	4 RW 5 RW	.463 .625	9/16 7/16	1-1/4 1-1/4	13/16 1-1/16	18-10060-17	18-78501 18-7712-3
18-7864 18-7872	1-14 1-14	6 RW 7 RW	.750 .875	3/4 3/4	1-1/4 1-1/4	1-3/4 2-1/8	18-10060-17	18-78650 18-78701

Use with Threaded Ejector Holder to make Replaceable Taper Holders

Part No.	Female Thd. Size	Barrel Dia.
18-275	1-14	1-1/4
18-276	1-14	1-1/2

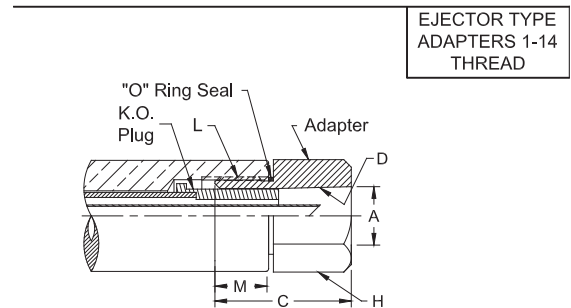

# 200 SERIES (EJECTOR) REPLACEMENT PARTS



Phone: 888-654-9353

Fax: 937-253-2324

Email: sales@productionengineering.com

## 200 SERIES (EJECTOR) WATER COOLED ELECTRODE HOLDER

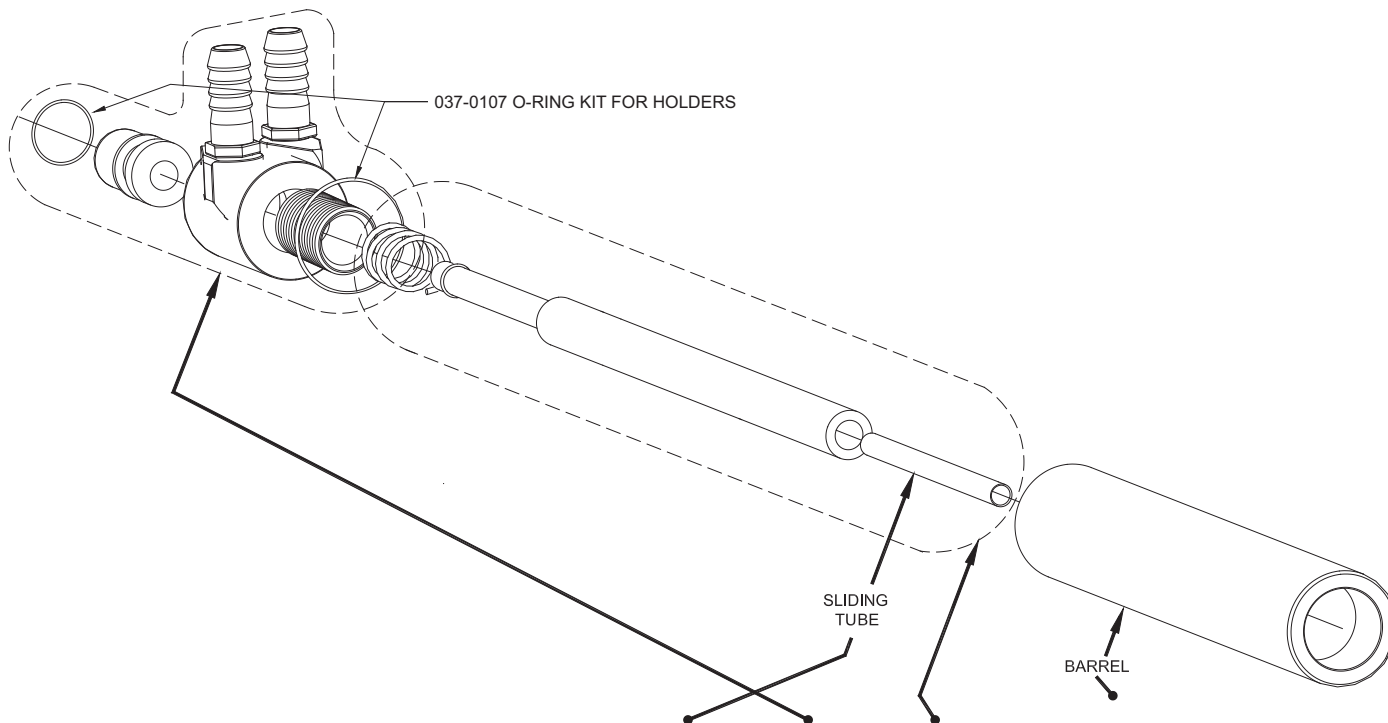

Part No. Holder Assy.	Thread Or Taper	Barrel Length	Sliding Tube	Water Conn. HD. Sub-Assy.	K.O. Tube Sub-Assy	Barrel Diameter	Barrel
18-201	4 RW	3	18-10046-3	18-20093	18-20095-3	3/4	18-11110-3
18-202				18-20093		7/8	18-11210-3
18-203				18-20091		1	18-11310-3
18-204				18-20091		1-1/4	18-11410-3
18-206	5 RW	3	18-10047-3	18-20092	18-20096-3	1	18-11610-3
18-207						1-1/4	18-11710-3
18-208						1-1/2	18-11810-3
18-211	4 RW	8	18-10046-8	18-20093	18-20095-8	3/4	18-11110-8
18-212				18-20093		7/8	18-11210-8
18-213				18-20091		1	18-11310-8
18-214				18-20091		1-1/4	18-11410-8
18-216	5 RW	8	18-10047-8	18-20092	18-20096-8	1	18-11610-8
18-217						1-1/4	18-11710-8
18-218						1-1/2	18-11810-8
18-219*	7 RW	8	18-10047-8	18-20092	18-20096-58	1-1/4	18-11910-8
18-220*						1-1/2	18-12010-8
18-231	4 RW	12	18-10046-8	18-20093	18-20095-12	3/4	18-11110-12
18-232				18-20093		7/8	18-11210-12
18-233				18-20091		1	18-11310-12
18-234				18-20091		1-1/4	18-11410-12
18-236	5 RW	12	18-10047-8	18-20092	18-20096-12	1	18-11610-12
18-237						1-1/4	18-11710-12
18-238						1-1/2	18-11810-12
18-236-18	5 RW	18	18-10047-29	18-20092	18-20096-18	1	18-11610-18
18-237-18						1-1/4	18-11710-18
18-238-18						1-1/2	18-11810-18
18-272	7/8-14	8	18-10047-8	18-20092	18-20096-8	1	18-17210-8
18-273						1-1/4	18-17310-8
18-274						1-1/2	18-17410-8
18-275	1-14	8	18-10047-8	18-20092	18-20096-8	1-1/4	18-17510-8
18-276						1-1/2	18-17610-8

\*Must use knockout adapter 18-20033